

SLEEVE-DRIVE SOCKETS

SLEEVE-DRIVE STECKSCHLÜSSEL

DOUILLES, SLEEVE DRIVE

3/8"

1/2"

3/4"



Sleeve-Drive Sockets
 Sleeve-Drive Steckschlüssel
 Douilles, Sleeve Drive



The deepened drive end of the **Sleeve-Drive** tools prevents the sometimes "wobbly" connection between pulse tool - extension - socket. An O-ring inside **Sleeve-Drive** optimizes the perfect fit of extension bars and sockets on the anvil to the effect, that the exactness of the required torque given by the pulse tool is generally improved. Further, the **Sleeve-Drive** avoids the direct transmission of vibrations on the pulse tool and finally on the operator.

Der **Sleeve-Drive** Vierkant-Antrieb vermeidet durch die vertiefte Passung den "Wackelkontakt" zwischen Maschine - Verlängerung - Steckschlüssel. Ein im **Antriebsende der Sleeve-Drive-Steckschlüssel** eingesetzter Ring optimiert den festen Sitz der Verlängerungen und Steckschlüssel auf der Schrauberspindel und sorgt somit für die unmittelbare Weitergabe des vorgegebenen Drehmomentes ohne wesentliche Drehkraftverluste. Nicht zuletzt vermeidet der **Sleeve-Drive** Antrieb die Übertragung von Schwingungen auf Mensch und Maschine.

Ces nouveaux outils **Sleeve-Drive** se caractérisent par un entraînement carré allongé et un joint torique incorporé. Le guidage rigide ainsi obtenu maintient les outils **Sleeve-Drive** dans l'axe de la broche de la machine et garantit une connection optimale machine-rallonges-douilles. Le jeu latéral et les vibrations engendrés par les outils traditionnels sont de ce fait supprimés. Il en résulte une transmission plus précise du coupe de serrage et un plus grand confort de travail pour l'opérateur.

Sleeve Drive Sockets

Wrenches

O-Ring

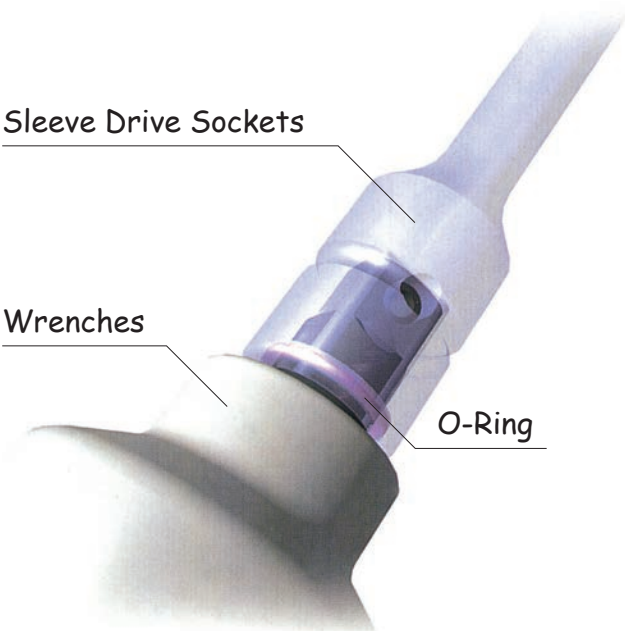

SLEEVE DRIVE SOCKET

PULSE TOOL

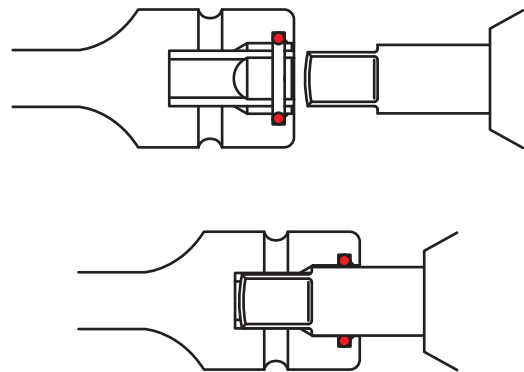

The "**Sleeve Drive**" Sockets and accessories are designed for use on Pulse Tools with anvils of certain lengths and diameters as shown hereunder.

Die serienmässigen "**Sleeve Drive**" Steckschlüssel können nur auf Impuls Schraubern mit Antriebswellen der nachstehenden Längen und Durchmesser gesteckt werden.

Les douilles "**Sleeve Drive**" ne peuvent être placées que sur des axes des boulonneuses à impulsions d'une longueur et d'un diamètre selon la spécification ci-dessous.

	Anvil Diameter (mm)	Minimum Anvil Length (mm)
3/8"sq.	12	10
1/2"sq.	16	10
3/4"sq.	25	11.8

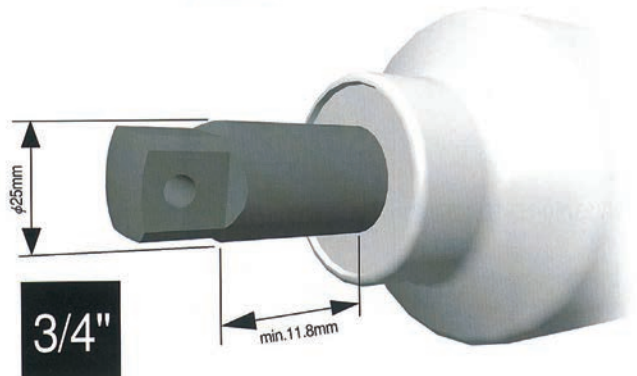
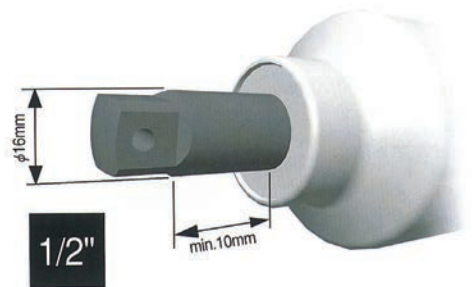
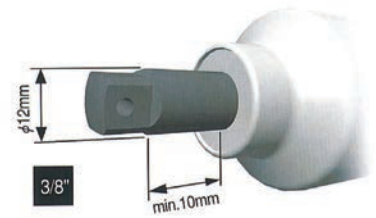

3/8"

Sleeve-Drive Sockets
Sleeve-Drive Steckschlüssel
Douilles, Sleeve Drive

NV13400 (mm)	D ₁ (mm)	D ₂ (mm)	H (mm)	L (mm)	(g)	(pcs.)	
8	13.3	19	6	43	53	10	*1
10	15.8	19	7	43	53	10	*1
11	17	19	8	43	54	10	*1
12	18.3	19	9	43	55	10	*1
13	19.5	22	10	43	80	10	*2
14	20.8	22	10	43	80	10	*2
15	22	22	11	43	81	10	*2
16	23.3	22	11	43	83	10	*2
17	24.5	22	11	43	85	10	*2
18	25.8	22	11	43	89	10	*2
19	27	22	11	43	98	10	*2
21	29.5	22	11	43	105	10	*2
22	30.8	22	11	43	112	10	*2

*1 C-Ring=1301C, Pin/O-Ring=1301A/B

*2 C-Ring=1302C, Pin/O-Ring=1302A/B

→ P254-255

NV13400

6-point Sockets
6-kant Steckschlüssel
Douilles 6-pans

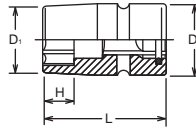

NV13145-100 (mm)	D ₁ (mm)	D ₂ (mm)	H (mm)	L (mm)	(g)	(pcs.)	
6	13	19	6	100	108	10	*1
8	13	19	8	100	110	10	*1
10	15.5	19	10	100	112	10	*1
12	18	19	12	100	120	10	*1
13	19	19	13	100	127	10	*1
14	21	19	14	100	131	10	*1
15	22	19	15	100	133	10	*1
16	24	19	15	100	144	10	*1
17	25	19	15	100	154	10	*1

NV13145-150 (mm)	D ₁ (mm)	D ₂ (mm)	H (mm)	L (mm)	(g)	(pcs.)	
6	13	19	6	150	160	10	*1
8	13	19	8	150	160	10	*1
10	15.5	19	10	150	165	10	*1
12	18	19	12	150	168	10	*1
13	19	19	13	150	170	10	*1
14	21	19	14	150	175	10	*1
15	22	19	15	150	177	10	*1
16	24	19	15	150	190	10	*1
17	25	19	15	150	203	10	*1

NV13145-200 (mm)	D ₁ (mm)	D ₂ (mm)	H (mm)	L (mm)	(g)	(pcs.)	
6	13	19	6	200	210	10	*1
8	13	19	8	200	210	10	*1
10	15.5	19	10	200	212	10	*1
12	18	19	12	200	214	10	*1
13	19	19	13	200	218	10	*1
14	21	19	14	200	220	10	*1
15	22	19	15	200	226	10	*1
16	24	19	15	200	235	10	*1
17	25	19	15	200	250	10	*1

*1 C-Ring=1301C, Pin/O-Ring=1301A/B

→ P254-255

NV13145-100 / -150 / -200

Extended Sockets
Schaftsteckschlüssel
Douilles rallongées

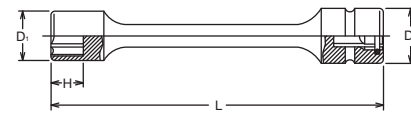

NV13760-75P	D (mm)	L (mm)	(g)	(pcs.)	
NV13760-75P	19	75	95	10	*1
NV13760-125P	19	125	125	10	*1
NV13760-150P	19	150	150	10	*1
NV13760-250P	19	250	255	10	*1

*1 C-Ring=1301C, Pin/O-Ring=1301A/B

→ P254-255

NV13760-P

Extension Bars
Verlängerungen
Rallonges



Z-SERIES
HAND
TITANIUM
ACCESSORIES
SCREWDRIVERS
IMPACT
SLEEVE-DRIVE
PROTECTOR
INDUSTRIAL
AUTOMOTIVE
MOTORCYCLE
CONSTRUCTION
SPARE PART

Z-SERIES
HAND
TITANIUM
SCREWDRIVERS ACCESSORIES
IMPACT
SLEEVE-DRIVE
PROTECTOR
INDUSTRIAL
AUTOMOTIVE
MOTORCYCLE
CONSTRUCTION
SPARE PART

183H-35 / -75 / -150

Hex Bits
Sechskant Bits
Embouts, 6 pans creux

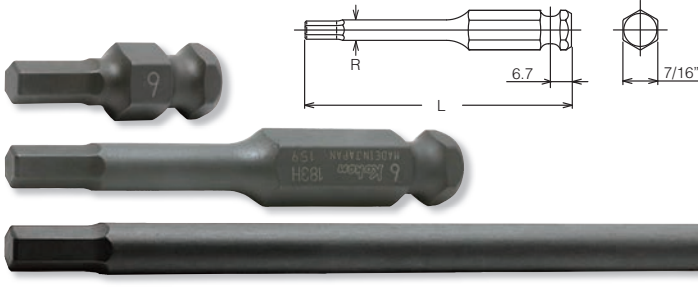

183H-35 (inch)	L (mm)	(g)	(pcs.)
3/16	35	15	10
7/32	35	16	10
1/4	35	18	10
5/16	35	20	10
3/8	35	26	10
7/16	35	28	10
1/2	35	38	10

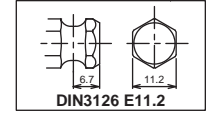

183H-35 (mm)	L (mm)	(g)	(pcs.)
3	35	15	10
4	35	15	10
5	35	15	10
6	35	18	10
7	35	19	10
8	35	20	10
New 9	35	23	10
10	35	26	10
11	35	28	10
12	35	30	10
14	35	35	10
16	35	47	10
17	35	50	10
18	35	53	10
19	35	56	10

183H-75 (mm)	L (mm)	R (mm)	(g)	(pcs.)
3	75	6	34	10
4	75	6	35	10
5	75	6.5	36	10
6	75	7.5	39	10
7	75	8.5	44	10
8	75	9.5	47	10
10	75	-	57	10
11	75	-	60	10
12	75	-	65	10
14	75	-	79	10

183H-150 (mm)	L (mm)	R (mm)	(g)	(pcs.)
4	150	6	51	10
5	150	6.5	55	10
6	150	7.5	65	10
8	150	9.5	87	10
10	150	-	118	10
12	150	-	136	10

183T-35 / -75 / -150 (T)

TORX® Bits
TORX® Bits
Embouts, TORX®

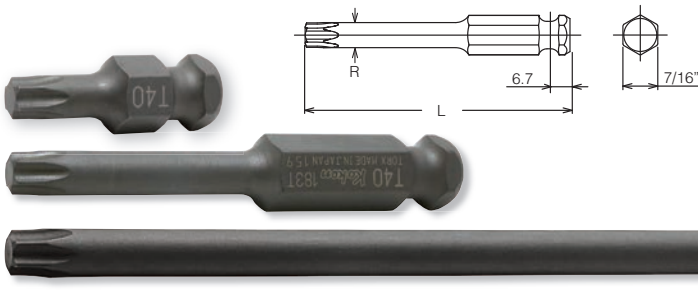

183T-35 (T)	L (mm)	(g)	(pcs.)
T25	35	18	10
T30	35	18	10
T40	35	20	10
T45	35	22	10
T50	35	26	10
T55	35	30	10
T60	35	38	10

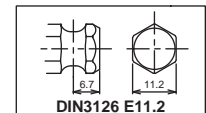

183T-150 (T)	L (mm)	R (mm)	(g)	(pcs.)
T30	150	6	50	10
T40	150	6.9	58	10
T45	150	8	70	10
T50	150	9	82	10
T55	150	11.4	113	10

183T-75 (T)	L (mm)	R (mm)	(g)	(pcs.)
T30	75	6	35	10
T40	75	6.9	37	10
T45	75	8	41	10
T50	75	9	45	10
T55	75	11.4	55	10
T60	75	13.5	67	10

183T-35 / -75 (IP)

TORXPLUS® Bits
TORXPLUS® Bits
Embouts TORXPLUS®

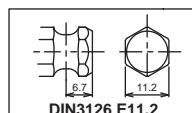
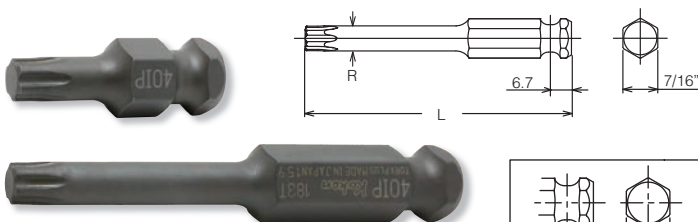

183T-35 (IP)	L (mm)	(g)	(pcs.)
30IP	35	18	10
40IP	35	20	10
45IP	35	22	10
50IP	35	26	10
55IP	35	30	10
60IP	35	38	10

183T-75 (IP)	L (mm)	R (mm)	(g)	(pcs.)
30IP	75	6	35	10
40IP	75	6.8	37	10
45IP	75	8	41	10
50IP	75	9	45	10
55IP	75	11.4	56	10
60IP	75	13.5	67	10

3/8", 1/2"

Sleeve-Drive Sockets
Sleeve-Drive Steckschlüssel
Douilles, Sleeve Drive

183X-35 (XZN)	L (mm)	(g)	(pcs.)
M 4	35	18	10
M 5	35	18	10
M 6	35	20	10
M 8	35	22	10
M10	35	26	10
M12	35	30	10
M14	35	38	10

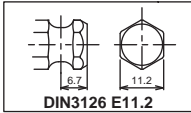

183X-35 / -75 / -150 (XZN)

XZN Bits
XZN Bits
Embouts, XZN

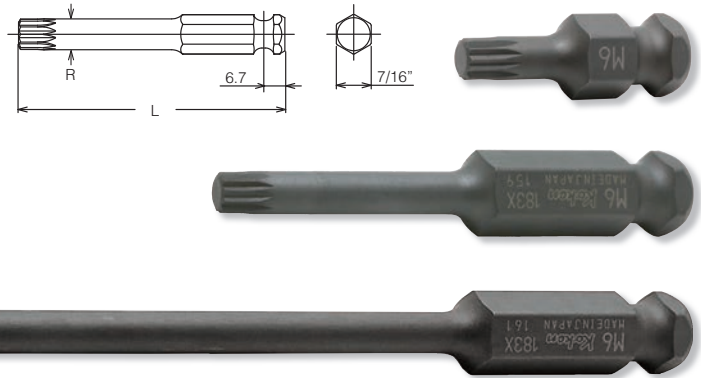

183X-75 (XZN)	L (mm)	R (mm)	(g)	(pcs.)
M 4	75	6	34	10
M 5	75	6	34	10
M 6	75	6.2	36	10
M 8	75	7.4	39	10
M10	75	9.8	54	10
M12	75	11.7	57	10
M14	75	13.5	67	10

183X-150 (XZN)	L (mm)	R (mm)	(g)	(pcs.)
M 5	150	6	50	10
M 6	150	6.2	53	10
M 8	150	7.4	64	10
M10	150	9.8	93	10
M12	150	11.7	121	10

	D ₁ (mm)	D ₂ (mm)	H (mm)	L (mm)	(g)	(pcs.)	
NV13134	22.5	22	15	45	100	5	*1

*1 C-Ring=1301C, Pin/O-Ring=1301A/B → P254-255

For DIN3126 E11.2 Bits
Für DIN3126 E11.2 Bits
Pour DIN3126 E11.2 Embouts

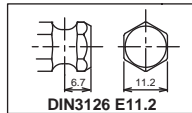

13134-SC

Replacement Screw : M8x5, ● 4mm

	D ₁ (mm)	D ₂ (mm)	H (mm)	L (mm)	(g)	(pcs.)	
NV14134	22.5	25	15	55	130	5	*1

*1 C-Ring=1401C, Pin/O-Ring=1401A/B → P254-255

For DIN3126 E11.2 Bits
Für DIN3126 E11.2 Bits
Pour DIN3126 E11.2 Embouts

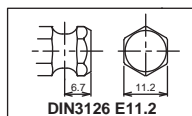

13134-SC

Replacement Screw : M8x5, ● 4mm

NV13134

Bit Holder
Klingenhalter
Porte-embouts

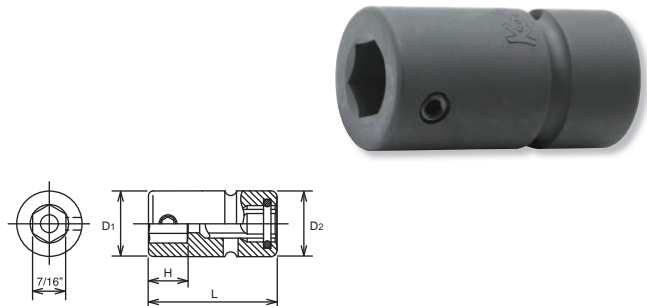

NV14134

Bit Holder
Klingenhalter
Porte-embouts

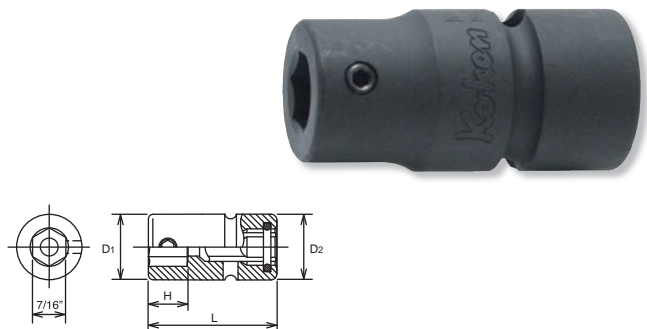

Z-SERIES
HAND
TITANIUM
ACCESSORIES
SCREWDRIVERS
IMPACT
SLEEVE-DRIVE
PROTECTOR
INDUSTRIAL
AUTOMOTIVE
MOTORCYCLE
CONSTRUCTION
SPARE PART

Sleeve-Drive Sockets

Sleeve-Drive Steckschlüssel

Douilles, Sleeve Drive

1/2"

Z-SERIES
HAND
TITANIUM
SCREWDRIVERS ACCESSORIES
IMPACT
SLEEVE-DRIVE
PROTECTOR
INDUSTRIAL
AUTOMOTIVE
MOTORCYCLE
CONSTRUCTION
SPARE PART

NV14400

6-point Sockets
6-kant Steckschlüssel
Douilles 6-pans

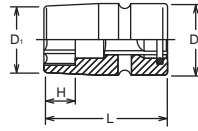

NV14400 (mm)	D ₁ (mm)	D ₂ (mm)	H (mm)	L (mm)	(g)	(pcs.)	
12	19.5	25	9	54	120	10	*1
13	20.7	25	10	54	120	10	*1
14	22	25	10	54	120	10	*1
15	23.2	30	11	54	188	10	*2
16	24.5	30	11	54	189	10	*2
17	25.7	30	12	54	190	10	*2
18	27	30	12	54	190	10	*2
19	28.2	30	12	54	190	10	*2
21	30.7	30	12	54	191	10	*2
22	32	30	12	54	192	10	*2
23	33.2	30	12	54	196	10	*2
24	34.5	30	12	54	200	10	*2

*1 C-Ring=1401C, Pin/O-Ring=1401A/B → P254-255
*2 C-Ring=1402C, Pin/O-Ring=1402A/B

NV14145-100 / -150 / -200

Extended Sockets
Schaftsteckschlüssel
Douilles rallongées



NV14145-100 (mm)	D ₁ (mm)	D ₂ (mm)	H (mm)	L (mm)	(g)	(pcs.)	
10	15.5	25	10	100	161	1	*1
12	18	25	12	100	178	1	*1
13	19	25	13	100	175	1	*1
14	21	25	14	100	181	1	*1
15	22	25	15	100	185	1	*1
16	24	25	15	100	193	1	*1
17	25	25	15	100	201	1	*1
18	26	25	15	100	211	1	*1
19	28	25	15	100	221	1	*1

NV14145-150 (mm)	D ₁ (mm)	D ₂ (mm)	H (mm)	L (mm)	(g)	(pcs.)	
10	15.5	25	10	150	200	1	*1
12	18	25	12	150	215	1	*1
13	19	25	13	150	220	1	*1
14	21	25	14	150	225	1	*1
15	22	25	15	150	230	1	*1
16	24	25	15	150	240	1	*1
17	25	25	15	150	250	1	*1
18	26	25	15	150	262	1	*1
19	28	25	15	150	275	1	*1

NV14145-200 (mm)	D ₁ (mm)	D ₂ (mm)	H (mm)	L (mm)	(g)	(pcs.)	
10	15.5	25	10	200	236	1	*1
12	18	25	12	200	250	1	*1
13	19	25	13	200	260	1	*1
14	21	25	14	200	270	1	*1
15	22	25	15	200	275	1	*1
16	24	25	15	200	287	1	*1
17	25	25	15	200	300	1	*1
18	26	25	15	200	310	1	*1
19	28	25	15	200	320	1	*1

*1 C-Ring=1401C, Pin/O-Ring=1401A/B → P254-255

NV14760-P

Extension Bars
Verlängerungen
Rallonges

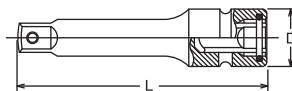

	D (mm)	L (mm)	(g)	(pcs.)	
NV14760-75P	25	75	149	10	*1
NV14760-125P	25	125	230	10	*1
NV14760-175P	25	175	308	10	*1
NV14760-250P	25	250	422	10	*1

*1 C-Ring=1401C, Pin/O-Ring=1401A/B → P254-255

NV14433A-P

Adaptors
Verbindungsstücke
Réducteurs

No Warranty
Keine Garantie
Sans Garantie



	(mm)	(mm)	L (mm)	(g)	(pcs.)	
NV14433A-75P	1/2"	3/8"	75	120	1	*1
NV14433A-100P	1/2"	3/8"	100	145	1	*1
NV14433A-150P	1/2"	3/8"	150	187	1	*1

*1 C-Ring=1401C, Pin/O-Ring=1401A/B → P254-255

⚠ Adapting down from bigger square drive to smaller square drive may lead to excessive torque load and possibly cause breakage. Always stay within safe torque of the smaller square drive.

Die mit ⚠ gekennzeichneten Artikel können bei Überbelastung zu Bruch gehen. Aus Gründen Ihrer eigenen Sicherheit sollten die betreffenden Werkzeuge nie ruckartig, sondern nach und nach belastet werden, um Bruch und damit verbundene mögliche Verletzungen zu vermeiden.

Il est possible d'appliquer aux articles marqués ⚠ des couples de serrage susceptibles d'occasionner leur rupture. Pour votre propre sécurité, veuillez toujours appliquer la charge d'une manière uniforme et progressive. Ceci pour éviter ruptures et accidents.

3/4"

Sleeve-Drive Sockets
Sleeve-Drive Steckschlüssel
Douilles, Sleeve Drive

NV16400 (mm)	D ₁ (mm)	D ₂ (mm)	H (mm)	L (mm)	(g)	(pcs.)	⚡
17	30	44	12	65	448	5	*1
18	31.3	44	13	65	470	5	*1
19	32.5	44	13	65	455	5	*1
21	35	44	15	65	472	5	*1
22	36.3	44	16	65	471	5	*1
23	37.5	44	16	65	471	5	*1
24	38.8	44	16	65	467	5	*1
26	41.3	44	16	65	477	5	*1
27	42.5	44	16	65	473	5	*1
28	43.8	44	16	68	483	5	*1
29	45	44	18	68	464	5	*1
30	46.3	44	18	68	492	5	*1
32	48.8	44	19	70	514	5	*1
33	50	44	20	70	564	5	*1
34	51.3	44	20	70	588	5	*1
35	52.5	44	20	70	593	5	*1
36	53.8	44	20	70	598	5	*1
38	56.3	44	20	72	670	2	*1
41	60	44	22	72	687	2	*1
46	66.3	44	23	77	906	2	*1
50	69	44	23	77	1116	2	*1

*1 C-Ring=1600C, Pin/O-Ring=1601A/B → P254-255

NV16400  6-point Sockets
6-kant Steckschlüssel
Douilles 6-pans

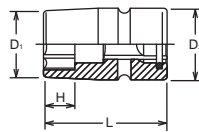

NV16760 Extension Bars
Verlängerungen
Rallonges



	D (mm)	L (mm)	(g)	(pcs.)	⚡
NV16760-175	44	175	870	1	*1
NV16760-250	44	250	1160	1	*1
NV16760-330	44	330	1460	1	*1

*1 C-Ring=1600C, Pin/O-Ring=1601A/B → P254-255

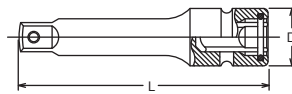

Z-SERIES
HAND
TITANIUM
ACCESSORIES
SCREWDRIVERS
IMPACT
SLEEVE-DRIVE
PROTECTOR
INDUSTRIAL
AUTOMOTIVE
MOTORCYCLE
CONSTRUCTION
SPARE PART

C-Ring Lock Clamps and Pullers
 Sicherungsklemmen und Abzieher
 Crochets de sécurité et extracteurs

Z-SERIES
 HAND
 TITANIUM
 SCREWDRIVERS ACCESSORIES
 IMPACT
 SLEEVE-DRIVE
 PROTECTOR
 INDUSTRIAL
 AUTOMOTIVE
 MOTORCYCLE
 CONSTRUCTION
 SPARE PART



One Piece solid springs steel ring. Simply set by finger pushing and easily removed by puller. Much more convenient and safer than combination of pin and o-ring.

Aus starkem Federstahl, in einem Stück. Bequem, mit einem Fingerdruck einzusetzen und mit dem Auszieher zu lösen. Einfacher und sicherer als die Kombination Stift und Ring.

Acier à ressorts, en une pièce. Mise en place d'une simple pression du pouce, enlèvement au moyen de la griffe d'extraction. Beaucoup plus facile et sûr que la combinaison goupille/bague.

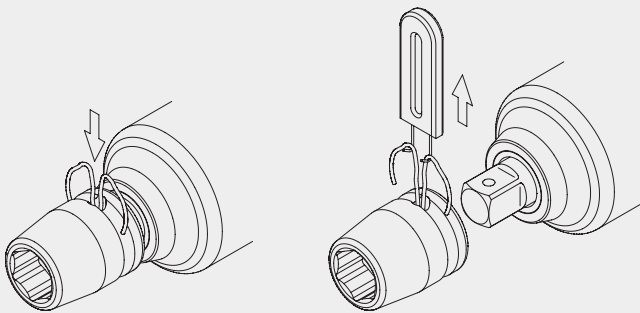

C-Ring

No.	□	Opening (mm)	📦 (pcs.)
1301C	3/8"	≤ 12	100
1302C	3/8"	> 12	100
1401C	1/2"	≤ 14	100
1402C	1/2"	> 14	100
1600C	3/4"	≤ 46	100
1801C	1"	≤ 70	100
1802C	1"	> 70	50
1700C	1-1/2"	≤ 90	50

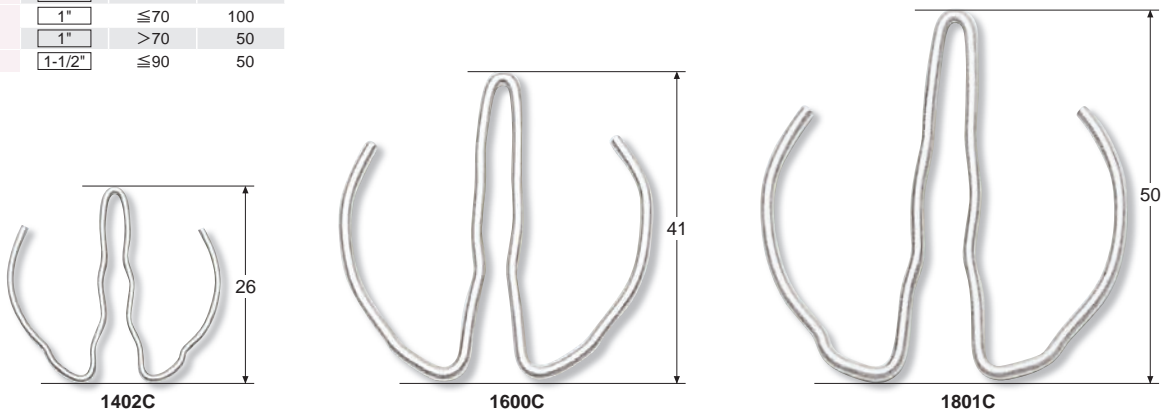
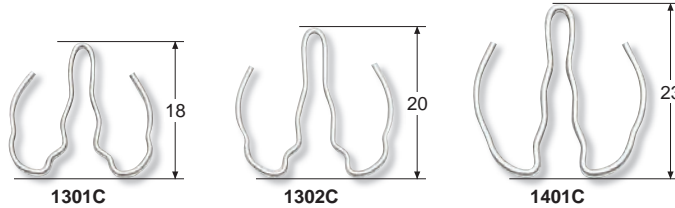

C-Ring Set

Set No.	□	C-Ring 10pcs.	Puller 1pce.
PK1301C	3/8"	1301C + 149	
PK1302C	3/8"	1302C + 149	
PK1401C	1/2"	1401C + 149	
PK1402C	1/2"	1402C + 149	
PK1600C	3/4"	1600C + 152	
PK1801C	1"	1801C + 152	

Puller

No.	□	□	📦 (pcs.)
149	3/8"	1/2"	10
152	3/4"	1"	10



149



152

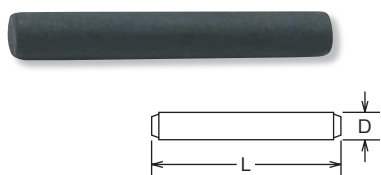

Pin

No.	□	Opening (mm)	D (mm)	L (mm)	pcs.
1200A	1/4"		1.5	10.2	100
1301A	3/8"	≤ 12	2.5	14.5	100
1302A	3/8"	> 12	2.5	17.5	100
1401A	1/2"	≤ 14	3.5	20	100
1402A	1/2"	> 14	3.5	25	100
1500A	5/8"		4	29	100
1601A	3/4"	≤ 46	5.5	35	100
1602A	3/4"	> 46	5.5	45	100
1801A	1"	≤ 70	6	45	100
1802A	1"	> 70	6	75	50
1701A	1-1/2"	≤ 90	7	75	50
1702A	1-1/2"	> 90	7	110	50
1901A	2-1/2"	≤ 115	9	110	50
1902A	2-1/2"	> 115	9	155	50
2001A	3-1/2"	≤ 140	13	155	1
2002A	3-1/2"	> 140	13	180	1

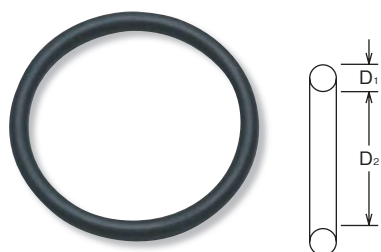

O-Ring

No.	□	Opening (mm)	D ₁ (mm)	D ₂ (mm)	pcs.
1200B	1/4"		2.5	9	100
1301B	3/8"	≤ 12	3.5	13	100
1302B	3/8"	> 12	3.5	16	100
1401B	1/2"	≤ 14	4	19	100
1402B	1/2"	> 14	4	24	100
1500B	5/8"		5	28	100
1601B	3/4"	≤ 46	5	36	100
1602B	3/4"	> 46	5	45	100
1801B	1"	≤ 70	7	45	100
1802B	1"	> 70	7	75	50
1701B	1-1/2"	≤ 90	10	75	50
1702B	1-1/2"	> 90	10	114	50
1901B	2-1/2"	≤ 115	10.5	114	50
1902B	2-1/2"	> 115	10.5	158	50
2001B	3-1/2"	≤ 140	15	158	1
2002B	3-1/2"	> 140	15	183	1



Pins & O Rings/C-Ring Lock Clamps
 Halteringe und Stifte/Sicherungsklemmen
 Goupilles et joncs/Crochets de sécurité

Z-SERIES
 HAND
 TITANIUM
 SCREWDRIVERS
 ACCESSORIES
 IMPACT
 SLEEVE-DRIVE
 PROTECTOR
 INDUSTRIAL
 AUTOMOTIVE
 MOTORCYCLE
 CONSTRUCTION
 SPARE PART

IMPACT Standard Sockets	Sq. Dr.	1/4"	3/8"		1/2"		3/4"		1"		1-1/2"	
		C-Ring	1301C	1302C	1401C	1402C	1600C	1801C	1801C	1802C	1700C	
		O-Ring/Pin	1200A/B	1301A/B	1302A/B	1401A/B	1402A/B	1601A/B	1602A/B	1801A/B	1802A/B	1701A/B
4		●										
4.5	3/16	●										
5		●										
5.5		●										
6	1/4	●	●		●							
7	9/32	●	●		●							
8	5/16	●	●		●							
9	11/32	●	●		●							
10	3/8	●	●		●							
11	7/16	●	●		●							
12		●	●		●							
13	1/2	●		●	●							
14	9/16	●		●	●		●					
15				●	●	●	●					
16	5/8			●	●	●	●		●			
17	11/16			●	●	●	●		●			
18				●	●	●	●		●			
19	3/4			●	●	●	●		●			
20				●	●	●	●		●			
21	13/16			●	●	●	●		●			
22	7/8			●	●	●	●		●			
23				●	●	●	●		●			
24	15/16			●	●	●	●		●			
25	1				●	●	●		●			
26					●	●	●		●			
27	1- 1/16				●	●	●		●			
28					●	●	●		●			
29	1- 1/8				●	●	●		●			
30	1- 3/16				●	●	●		●			
31					●	●	●		●			
32	1- 1/4				●	●	●		●			
33	1- 5/16				●	●	●		●			
34	1- 3/8				●	●	●		●			
36					●	●	●		●			
37	1- 7/16				●	●	●		●			
38	1- 1/2				●	●	●		●			
39					●	●	●		●			
40	1- 9/16				●	●	●		●			
41	1- 5/8				●	●	●		●			
42					●	●	●		●			
43	1- 11/16				●	●	●		●			
44					●	●	●		●			
45	1- 3/4				●	●	●		●			
46	1- 13/16				●	●	●		●			
47					●	●	●		●			
48	1- 7/8				●	●	●		●			
	1- 15/16				●	●	●		●			
50					●	●	●		●			
	2				●	●	●		●			
52	2- 1/16				●	●	●		●			
54	2- 1/8				●	●	●		●			
55	2- 3/16				●	●	●		●			
56					●	●	●		●			
	2- 1/4				●	●	●		●			
58	2- 5/16				●	●	●		●			
60	2- 3/8				●	●	●		●			
62	2- 7/16				●	●	●		●			
63					●	●	●		●			
	2- 1/2				●	●	●		●			
65	2- 9/16				●	●	●		●			
67	2- 5/8				●	●	●		●			
68	2- 11/16				●	●	●		●			
70	2- 3/4				●	●	●		●			
	2- 13/16				●	●	●		●			
	2- 7/8				●	●	●		●			
75	2- 15/16				●	●	●		●			
	3				●	●	●		●			
	3- 1/16				●	●	●		●			
80	3- 1/8				●	●	●		●			
	3- 1/4				●	●	●		●			
85					●	●	●		●			
	3- 3/8				●	●	●		●			
90	3- 1/2				●	●	●		●			
	3- 5/8				●	●	●		●			
95	3- 3/4				●	●	●		●			
100	3- 7/8				●	●	●		●			
105	4				●	●	●		●			
	4- 1/8				●	●	●		●			
110	4- 1/4				●	●	●		●			
115	4- 1/2				●	●	●		●			
120	4- 5/8				●	●	●		●			
	4- 3/4				●	●	●		●			
125	4- 7/8				●	●	●		●			
130	5				●	●	●		●			
135	5- 1/4				●	●	●		●			
140					●	●	●		●			
150					●	●	●		●			
	6				●	●	●		●			
	6- 1/2				●	●	●		●			