

**SOCKETS WITH TURNABLE PLASTIC PROTECTORS**  
**STECKSCHLÜSSEL MIT DREHBAREN SCHUTZHÜLSEN AUS KUNSTSTOFF**  
**DOUILLES A PROTECTIONS PLASTIFIEES**



Z-SERIES  
 HAND  
 TITANIUM  
 ACCESSORIES  
 SOREWDRIERS  
 IMPACT  
 SLEEVE-DRIVE  
 PROTECTOR  
 INDUSTRIAL  
 AUTOMOTIVE  
 MOTORCYCLE  
 CONSTRUCTION  
 SPARE PART



**Safety**

Turnable plastic protector increases operator's safety during assembly process.

Unsere drehbaren Kunststoff-Hülsen erhöhen die Arbeitssicherheit während des Montageprozesses.

Nos protections rotatives plastifiées augmentent la sécurité lors du montage.



**Scratch proof**

Protector helps to reduce the possibility giving damage on painted, polished and sensitive surfaces. Protector is free rotation designed.

Die Protektoren vermeiden Beschädigungen an lackierten-, polierten- bzw. empfindlichen Oberflächen. Unsere Protektoren sind frei drehbar.

Les protections évitent des endommagements sur des surfaces laquées, polies ou sensibles. Nos protections ont une libre rotation.

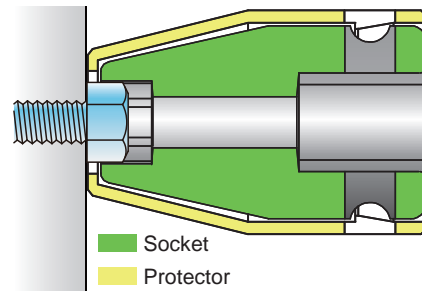

13400M (mm)	D <sub>1</sub> (mm)	D <sub>2</sub> (mm)	H (mm)	L (mm)	(g)
8FR	15.7	22	6	33.3	40
10FR	18.2	22	7	33.3	40
12FR	20.8	22	9	33.3	43
13FR	21.8	25	10	33.3	56
14FR	23.6	25	10	33.3	56
16FR	26.1	25	11	33.3	57
17FR	27.3	25	12	33.3	60



## 13400M-FR

6-point Sockets  
6-kant Steckschlüssel  
Douilles 6-pans

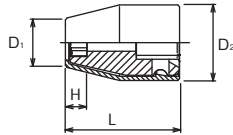

13300M (mm)	D <sub>1</sub> (mm)	D <sub>2</sub> (mm)	H <sub>1</sub> (mm)	H <sub>2</sub> (mm)	L (mm)	(g)
New 8FR	16.1	22	9	67.5	81.3	87
New 10FR	18.6	22	11	67.5	81.3	99
New 12FR	21.1	22	13	67.5	81.3	116
New 13FR	22.3	25	14	67.5	81.3	143
New 14FR	23.6	25	15	67.5	81.3	153
New 16FR	26	25	17	66.5	81.3	161
New 17FR	27.2	25	18	66.5	81.3	173

## 13300M-FR

6-point Sockets, deep  
6-kant Steckschlüssel, lang  
Douilles longues, 6-pans

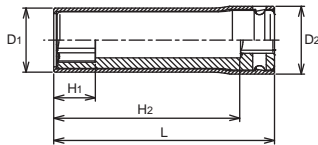

13300G (mm)	D <sub>1</sub> (mm)	D <sub>2</sub> (mm)	H <sub>1</sub> (mm)	H <sub>2</sub> (mm)	L (mm)	(g)
New 8FR	16.1	22	5	27.5	81.3	87
New 10FR	18.6	22	5.5	27	81.3	110
New 12FR	21.1	22	7	27	81.3	141
New 13FR	22.3	25	7.5	26	81.3	170
New 14FR	23.6	25	8	25	81.3	191
New 16FR	26	25	8.5	28	81.3	215
New 17FR	27.2	25	9	28	81.3	225

## 13300G-FR

Impact Socket with Sliding Magnet  
Impact Steckschlüssel mit versenkbarem Magnet  
Douilles Impact avec aimant, glissant pour écrous

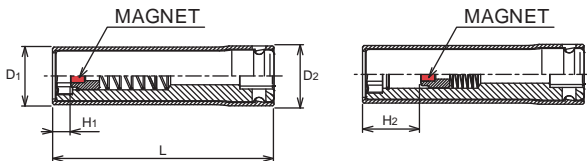

	D (mm)	L (mm)	(g)
13760-75P.FR	26.2	75	100
13760-125P.FR	26.2	125	145
13760-250P.FR	26.2	250	220

## 13760-P.FR

Extension Bars  
Verlängerungen  
Rallonges

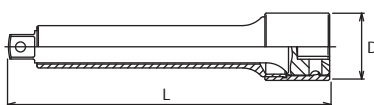

The protector could be broken with any impacts. Please handle with care.

Z-SERIES  
 HAND  
 TITANIUM  
 ACCESSORIES  
 SCREWDRIVERS  
 IMPACT  
 SLEEVE-DRIVE  
 PROTECTOR  
 INDUSTRIAL  
 AUTOMOTIVE  
 MOTORCYCLE  
 CONSTRUCTION  
 SPARE PART

## 14400M-FR

6-point Sockets  
 6-kant Steckschlüssel  
 Douilles 6-pans



14400M (mm)	D <sub>1</sub> (mm)	D <sub>2</sub> (mm)	H (mm)	L (mm)	(g)
10FR	19.5	28	7	39.3	90
12FR	22	28	9	39.3	90
13FR	23.2	28	10	39.3	90
14FR	24.8	28	11	39.3	90
16FR	27	33	10	39.3	135
17FR	28.2	33	12	39.3	135
19FR	31	33	13	39.3	130

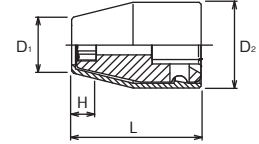

## 14300M-FR

6-point Sockets, deep  
 6-kant Steckschlüssel, lang  
 Douilles longues, 6-pans



14300M (mm)	D <sub>1</sub> (mm)	D <sub>2</sub> (mm)	H <sub>1</sub> (mm)	H <sub>2</sub> (mm)	L (mm)	(g)
New 10FR	19.8	28	11	63	81.3	145
New 12FR	22.3	28	13	63	81.3	167
New 13FR	23.5	28	14	63	81.3	167
New 14FR	24.8	28	15	63	81.3	179
New 16FR	27.3	33	17	63	81.3	237
New 17FR	28.5	33	18	63	81.3	237
New 19FR	31	33	20	62	81.3	245

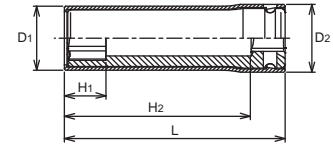

## 14300G-FR

Impact Socket with Sliding Magnet  
 Impact Steckschlüssel mit versenkbarem Magnet  
 Douilles Impact avec aimant, glissant pour écrous

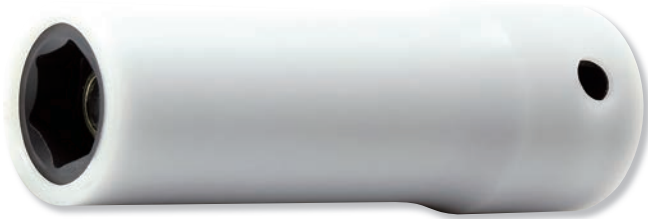

14300G (mm)	D <sub>1</sub> (mm)	D <sub>2</sub> (mm)	H <sub>1</sub> (mm)	H <sub>2</sub> (mm)	L (mm)	(g)
New 10FR	19.8	28	5.5	27	81.3	145
New 12FR	22.3	28	7	27	81.3	170
New 13FR	23.5	28	7.5	26	81.3	190
New 14FR	24.8	28	8	25	81.3	194
New 16FR	27.3	33	8.5	27.5	81.3	275
New 17FR	28.5	33	9	27.5	81.3	277
New 19FR	31	33	10	28.5	81.3	313

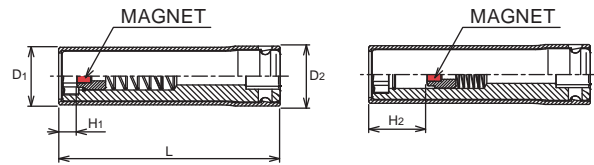

## 14760-P.FR

Extension Bars  
 Verlängerungen  
 Rallonges



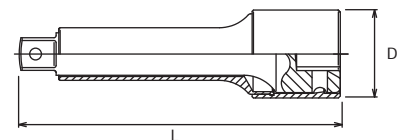

	D (mm)	L (mm)	(g)
14760-75P.FR	34.2	75	195
14760-125P.FR	34.2	125	280
14760-250P.FR	34.2	250	480





The protector could be broken with any impacts. Please handle with care.

### 113-75SV / -100SV / -150SV

 Nut Setters  
 Steckschlüssel Klingen  
 Embouts pour écrous 



113-75 (mm)	D (mm)	H (mm)	L (mm)	 (g)
<b>8SV</b>	15.1	6	75	34
<b>10SV</b>	16.9	7	75	37
<b>12SV</b>	19.4	8	75	44
<b>13SV</b>	20.4	8	75	45

113-100 (mm)	D (mm)	H (mm)	L (mm)	 (g)
<b>8SV</b>	15.1	6	100	43
<b>10SV</b>	16.9	7	100	47
<b>12SV</b>	19.4	8	100	54
<b>13SV</b>	20.4	8	100	55

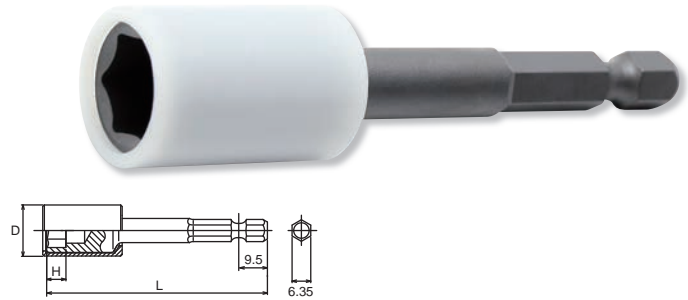
113-150 (mm)	D (mm)	H (mm)	L (mm)	 (g)
<b>8SV</b>	15.1	6	150	62
<b>10SV</b>	16.9	7	150	66
<b>12SV</b>	19.4	8	150	72
<b>13SV</b>	20.4	8	150	80



### 115-75SV / -100SV / -150SV

 Nut Setters with Magnet  
 Steckschlüssel Klingen mit Magnet  
 Embouts avec aimant pour écrous  



115-75 (mm)	D (mm)	H (mm)	L (mm)	 (g)
<b>8SV</b>	15.1	3.5	75	35
<b>10SV</b>	16.9	4.2	75	40
<b>12SV</b>	19.4	5.6	75	48
<b>13SV</b>	20.4	6	75	54

115-100 (mm)	D (mm)	H (mm)	L (mm)	 (g)
<b>8SV</b>	15.1	3.5	100	44
<b>10SV</b>	16.9	4.2	100	52
<b>12SV</b>	19.4	5.6	100	60
<b>13SV</b>	20.4	6	100	67

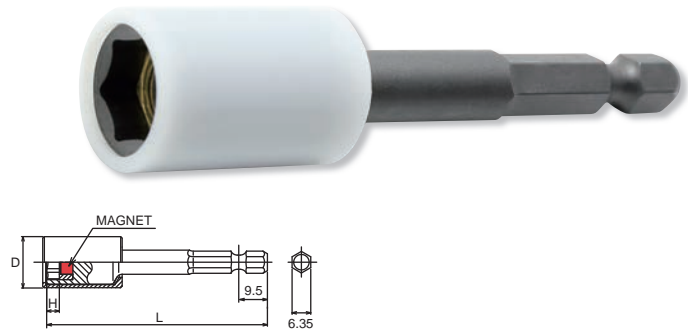
115-150 (mm)	D (mm)	H (mm)	L (mm)	 (g)
<b>8SV</b>	15.1	3.5	150	63
<b>10SV</b>	16.9	4.2	150	70
<b>12SV</b>	19.4	5.6	150	79
<b>13SV</b>	20.4	6	150	87



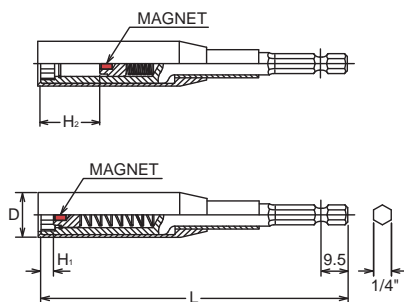

### 115G-100FR / -150FR / -200FR

 Nut Setters with sliding Magnet  
 Steckschlüssel Klingen mit versenkbarem Magnet  
 Embouts avec aimant, glissant pour écrous  



115G-100 (mm)	D (mm)	H <sub>1</sub> (mm)	H <sub>2</sub> (mm)	L (mm)	 (g)
<b>8FR</b>	15.1	4	26	100	55
<b>10FR</b>	16.9	4.5	26	100	60
<b>12FR</b>	19.3	6	26	100	80
<b>13FR</b>	20.4	6.5	25	100	85

115G-150 (mm)	D (mm)	H <sub>1</sub> (mm)	H <sub>2</sub> (mm)	L (mm)	 (g)
<b>8FR</b>	15.1	4	26	150	75
<b>10FR</b>	16.9	4.5	26	150	80
<b>12FR</b>	19.3	6	26	150	100
<b>13FR</b>	20.4	6.5	25	150	110

115G-200 (mm)	D (mm)	H <sub>1</sub> (mm)	H <sub>2</sub> (mm)	L (mm)	 (g)
<b>8FR</b>	15.1	4	26	200	90
<b>10FR</b>	16.9	4.5	26	200	100
<b>12FR</b>	19.3	6	26	200	125
<b>13FR</b>	20.4	6.5	25	200	135



 The protector could be broken with any impacts. Please handle with care.





Specifications or design of any product in this catalogue are subject to change without notice.

Wir behalten uns das Recht vor, jedes in diesem Katalog gezeigte Werkzeug, auch ohne vorherige Ankündigung, in Ausführung und Design ändern zu dürfen.

Nous nous réservons le droit de modifier les modèles et les dimensions des outils présentés dans ce catalogue et ce sans autre notification préalable.



**REPLACEMENT**

Remove a damaged Protector and put a new Protector on socket / Extension bar by pressing. For your safety, worn out or cracked Protector must be replaced.

**AUSTAUSCH**

Entfernen Sie defekte Protektoren und ersetzen Sie diese auf Ihrem Steckschlüssel/Verlängerung mittels einer Presse. Bitte tauschen Sie zu Ihrer Sicherheit verschlissene Protektoren aus !

**REPLACEMENT**

Retirez les protections défectueuses, remplacez celles-ci et fixez-les sur les douilles/rallonges à l'aide d'une presse. Pour votre sécurité remplacez toute protection défectueuse.